

Miłosz KRYSIK¹, Krzysztof PIOTROWSKI¹, Ryszard RYBSKI²

¹*IHP – Leibniz-Institut für innovative Mikroelektronik,
Frankfurt (Oder), Germany*

²*Uniwersytet Zielonogórski,
Instytut Metrologii Elektroniki i Informatyki*

GENERIC ENERGY PRODUCTION MODEL FOR SMART GRID EMULATION

This work describes the progress towards creating a model of energy production block to be applied in a smart grid emulator. This block allows reflecting the behavior of many energy production cases and by that enables defining multiple test scenarios for evaluating energy management Algorithms. The model is configurable and the behavior is adjustable in run-time. Control layers of emulator are described, suggesting how they can be embedded in the context of the power grid system. The commonly used methods of current and voltage regulation are discussed and the selected method is described in detail. The scheme and algorithm of synchronization with the network and detection of island operation is presented. The article ends with the results achieved so far, including the correct regulation of inverter parameters, synchronization with the network, as well as island operation detection.

OGÓLNY MODEL PRODUCENTA ENERGII DLA EMULATORA INTELIWENTNYCH SIECI ENERGETYCZNYCH(POJEDYWCZY)

Artykuł przedstawia postępy prac w kierunku stworzenia modelu bloku producenta energii, który będzie użyty jako część emulatora inteligentnych sieci energetycznych (smart grid). Blok ten umożliwia odwzorowanie zachowania wielu różnych przypadków produkcji energii i dzięki temu zdefiniowanie wielu scenariuszy testowych w celu ewaluacji algorytmów zarządzania energią. Model jest konfigurowalny i zmiana zachowania może być dokonywana w czasie jego pracy. Opisane zostały poszczególne warstwy sterowania emulatorem z zaproponowaniem jak osadzone mogą być w kontekście systemu sieci elektroenergetycznej. Zostały omówione wykorzystywane metody regulacji prądu i napięcia oraz opisana szczegółowo została wybrana metoda. Przedstawiony został schemat i algorytm synchronizacji z siecią, jak i wykrywania pracy wyspowej. Artykuł kończy dotychczas osiągnięte wyniki, między innymi poprawna regulacja parametrów falownika, synchronizacja z siecią, jak i wykrywanie pracy wyspowej.

1. MOTIVATION

Currently, the importance of distributed renewable energy resources in the energy grid rapidly grows. Poland, as a member of the European Union, has obligations regarding balancing energy related to greenhouse gases emission. What is more, the increase in energy demand can be observed, especially in developing countries [1]. These requirements influence changing the structure of the traditional utility to more intelligent and focus more on the consumer. This work presents the requirements and methods for modeling distributed energy generation devices that may be used in an energy grid model to define a diversity of test scenarios for energy management evaluation. These energy generators include, for instance, inverters with an optimized control strategy for both islanded and grid-synchronized operations. However, the supported device set is not limited to inverters and almost any generator class can be modeled. In the low-voltage energy grid emulator, these models allow testing how the energy grid behaves under various test conditions. The advantage of the emulator is that it allows defining scenarios usually not allowed in the real grid.

There is no absolute definition of the Smart Grid (SG), only the policies, however, the International Energy Agency, the U.S. Department of Energy, the European Technology Platform, and other organizations agreed [2] [3], that the SG can be described as follows. It is an electricity network that relies on an intelligent integration of all the actions involving every kind of user, like generators, consumers, or prosumers. The main principle of SG is to ensure sustainable, efficient, economic and secure electricity supply. It must calculate the most economical scenario based on the present condition, history, and forecast demand. The given modules of SG should with the use of smart meters exchange the critical parameter by communication between them to obtain the right parameters of controlling strategy. What distinguishes SG from the regular grid is that the SG is more flexible, making it possible to connect additional users. Further, SG allows new users to play a role in optimizing the system by making their resources available. Also, the SG must be resilient to cyberattacks and natural disasters. To meet these conditions advanced control strategies and management algorithms need to be applied.

Microgrid (MG) is a local, low-voltage system that consists of energy sources, like photovoltaic panels, wind turbines, or fuel cells connected by the appropriate converter to the loads within the network. The MG includes also storage devices, for example, flywheels, batteries, super-capacitors. It can be synchronized with the grid or operate as an island [4]. A static switch con-

trols the transition between these modes. Growing interest gains the concept of direct current (DC) MG, where only a rectifier and a DC/DC converter are needed to produce the energy, but this subject is out of the scope of this article.

When the MG operates in grid-connected mode, the energy consumer within MG is tied with the main grid. If the consumer could be fully powered by the power grid, then the local source within the MG is disconnected. Local sources can also split the delivery of the energy with the main grid. Further, whilst the energy production from MG is enough, it can fully power the local consumers and, if possible, even inject the surplus energy to the main system. Grid-synchronization systems require the control parameters of the energy signals to meet the conditions defined by the standards. The most crucial parameter is the phase angle. Grid synchronization usually uses a phase-locked loop (PLL). PLL with adaptive notch filtering and second-order generalized integrator-based PLL are the most common approaches in single-phase systems [5]. There are also methods without PLL, like the zero-crossing method [6] or Fourier analysis [7].

Island operation occurs when the MG is not connected to the main grid and the MG control unit is obligated to maintain the proper energy parameters. Within this mode, the amount of power that can be generated from local sources must be sufficient to cover all the needs of the MG. To ensure appropriate parameters of the energy quality, the variety of droop methods can be involved [4].

The SmartGrid subject is currently very important for the society and is supported by many research groups. The work described here was realized within the cooperation between the IHP and the University of Zielona Gora in their Joint Lab on distributed measurement systems. The SmartGrid emulator described in this article is an innovative means to investigate and evaluate energy management algorithms for SmartGrid. The emulator is a complex distributed system that includes the emulating part and the distributed measurement system part to model and capture the SmartGrid behavior.

2. PRINCIPLES OF OPERATION OF THE SMARTGRID EMULATOR

The proposed approach of the SmartGrid Emulator [8] works with the 24V AC voltage for the low voltage (LV) grid level and with 48V AC voltage for the medium voltage (MV) level with 50Hz frequency. This allows the system model to be more safe and still allows voltage transformations by using AC.

The idea of the emulator is to build the desired grid topology using a pre-defined set of building blocks. Executing energy management algorithms on the management units available on the active blocks [9] allows performing tests revealing the performance of the algorithms. There are four classes of building blocks: 1) the primary substation, 2) the secondary substation, 3) the transmission line, and 4) the prosumer block. All of them, except the transmission lines include a management unit that can run energy management algorithms. Fig. 1 presents an example topology created using the emulator building blocks.

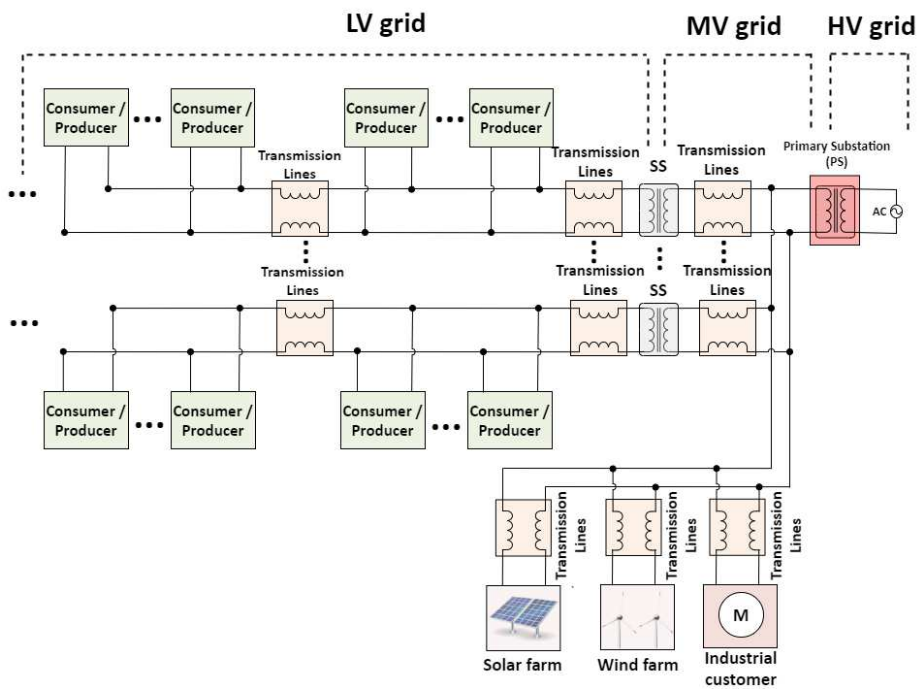

Fig. 1. An example energy grid topology
Rys. 1. Przykład topologii sieci energetycznej

The major part of the SmartGrid Emulator is the prosumer block. The prosumer is an active participant, who may both consume and produce the energy. It can be characterized as a small household with solar panels on the roofs, as well as a factory with own wind turbines, solar cells, and storage devices. Depending on the desired level of emulation the prosumer block can correspond to a single household or to larger microgrids to be emulated. It consists of the components allowing emulating the energy consumption and energy production and is indeed reflecting a single instance of a MG.

The diagram of possible connections within the emulated MG is presented in Fig. 2. The flexibility of the emulator is that it can be configured to emulate a variety of energy sources. There could be either DC (PV panels, batteries) or AC (wind turbine, small plants).

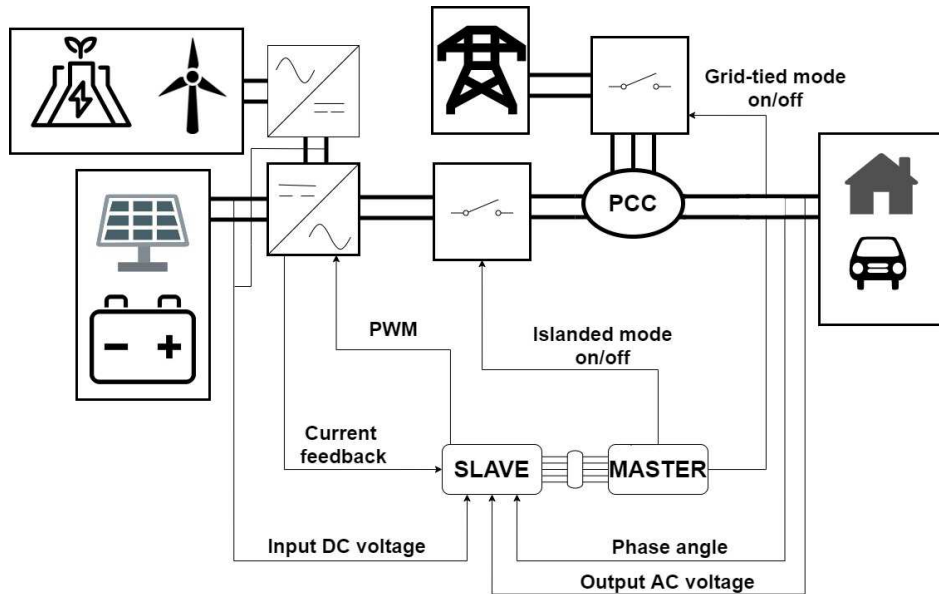

Fig. 2. Diagram of an example Micro Grid
Rys. 2. Schemat blokowy przykładowej Mikrosieci

In the real energy grid the energy from an exemplary source must be converted to a suitable voltage level, frequency, and phase angle. The energy from DC sources is transferred directly to the inverter, and the energy from AC sources generally is converted first to DC, then back again by the inverter to AC with the suitable parameters. It is important that different energy sources may express different behavior, e.g., in case of load variations. All these aspects need to be covered by the energy production module (converter) on the prosumer block. In the emulator the energy generation is powered from a DC source, but the converter has to reflect the features of the emulated sources.

The module with the converter is controlled by the control unit, that is sensing all the parameters essential for producing energy on demand level. That part consists of all the current, voltage, and phase angle sensors to thoroughly measure those parameters and send the data to the controller. Based on that data,

the controller is computing the parameters to produce a PWM signal that drives the transistors from the converter/inverter. The task of the controller is also the decision of mode operation.

At the point, where the MG is connected to the main grid, usually the switches are located to control the connection of the local resources and the main grid. These switches in the most basic form can be circuit breakers, although most of the system use the static switch, which is composed of a triac that can support large currents. Besides those techniques, the Solid State Transformer can be applied. It is an alternative for a conventional transformer. It has a smaller size, but the drawback is that it requires conversion voltage beforehand from AC to DC.

Focusing on the distributed energy production and with the knowledge of all the involved modules, a generic architecture of the control can be introduced. It is important to know the control tasks and signals to be generated on each level and what are the allowed control delays. The overview of the layers is presented in the Fig. 3.

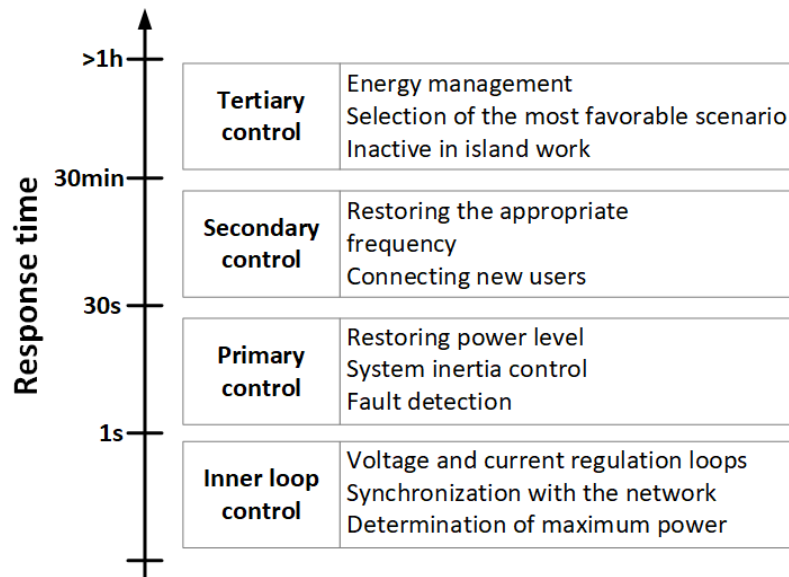

Fig. 3. Hierarchy control
Rys. 3. Hierarchia sterowania

3. THE INVERTER

The proposed approach of the SmartGrid Emulator [8] works with the 24V AC voltage for the low voltage (LV) grid level in a variety of aspects. Starting with the input energy, the inverter should be able to generate energy like it was transmitted directly from the DC source like PV panels or batteries, and energy that comes from AC sources and is transformed to DC energy like wind turbines or small power plants. The same is true for the load. The momentary demand has to be met irrelevant with the character and value of the load. The emulator, and precisely the control unit, has to be able to implement different strategies for controlling the main parameters of the inverter system that is voltage, current, and phase, and computing parameters in real-time, that are sensed in the system. The inverter should be able to work in four-quadrant, that is it can not only supply the load but also give the energy back to the system. Here it is crucial that multiple inverters can work in parallel without any issues. Thus, the flexibility is required by the basic goal of the emulator – the ability to support as many different test scenarios as possible, even those that are not visible to the designers of the emulator at the current moment.

3.1. Microgrid control

The control of the inverter model amounts to the tasks defined by the microgrid control tasks. Thus, for such a distributed system the levels of control and the parameters need to be properly defined and addressed.

3.1.1. Primary control strategies

There is a variety of strategies to control power in the MG. For the time being, there is no standard document that sets out the requirements for the control strategy. Since most MGs may differ depending on the potential for renewable resources and the demand loads, it is possible that regulation of these strategies will not take place soon. As a result, many different strategies have been implemented and new ones are still emerging. Some of the most commonly used strategies are compared in [8].

There are two main categories of controlling the MG with the microinverters: control-based communication and control without communication. Control without communication is indeed cheaper and does not require a large number of peripheral devices, but in a complex microgrid with multiple generators or when synchronization with the network is possible, this solution

does not seem appropriate. Control schemes without communication mainly consist of the droop control. So far, the varieties of these droop controls have prevailed in the current solutions. The most commonly used method is the P-Q Droop Control. However, it has some disadvantages, such as lower transient responses and inability to shape proper harmonic current. Therefore, many extensions of this method have been proposed, such as Power-voltage or Voltage-current droop. On the other hand, communication-based control like master/slave, or distributed control are an excellent tool to share power between the network and the inverters or to operate multiple inverters in parallel. Although, the additional communication system causes further costs and can cause problems with the network expansion.

3.1.2. Inner loop control strategies

In the described system, all power control methods are based on voltage or current control strategies that are based on closed-loop feedback systems. The main purpose of these loops is to deliver the signal error to the control unit after it is transmitted through the control block. This is to improve the quality of the generated signals and to respond to voltage or current interference from both, the power source and load. The following sections will describe some of the most useful methods.

One of the unique and widely used approaches is the proportional-integral (PI) controller. This type of controller can be described using the transfer function as follows: where K_P and K_I are proportional and integral gain, respectively. This controller is used very often for different purposes. It can, for example, control PWM parameters, regulate voltages, or even help in Phase-Locked Loop for grid synchronization. The controller can buck or boost the signal for improving and regulate control parameters.

Another approach for controlling power is proportional-resonant control (PR). That strategy can be implemented with the use of resonant frequency ω_r and its transfer function that is described as follows: $C_{PR} = K_P + K_I s/s^2 + \omega_r^2$. The main idea of a PR Controller is to apply an infinite gain at a selected frequency to eliminate steady-state DC error. The PR Controller is more complex in tuning parameters and stability analysis.

The next interesting approach is the Deadbeat controller. The main advantage of this strategy is a fast dynamic response that can eliminate errors within a finite number of cycles. The drawback of this controller is the requirement of the accurate filter model which is more demanding than the one in the

PR controller, and high sensitivity to feedback signal variations due to high gain.

H-Infinity Controller along with repetitive controllers are examples of robust control. It has a great adaptation for worst-case scenarios, so it finds an application in slower loops for fault detections.

Some additional approaches using machine learning theory like neural networks or fuzzy logic can be implemented, but it reaches out of the scope of this thesis.

3.1.3. Current and voltage controller – physical implementation

The selected method for controlling power uses the principle of the cascade method. The approach used in the emulator requires two loops that are voltage and current. When these loops will be correctly optimized, then the quality of power will reach a suitable level. To ensure it, both the inverter current and the output voltage have to be controlled. Also, the system should be able to respond to input voltage disturbances, for example, when non-dispatchable resources change their level of generated power. The changes in load should be likewise compensated in the Current Control Loop and hold fixed output root-mean-square voltage. To meet these criteria, an internal control loop is required. The proposed loops are presented in Fig. 4.

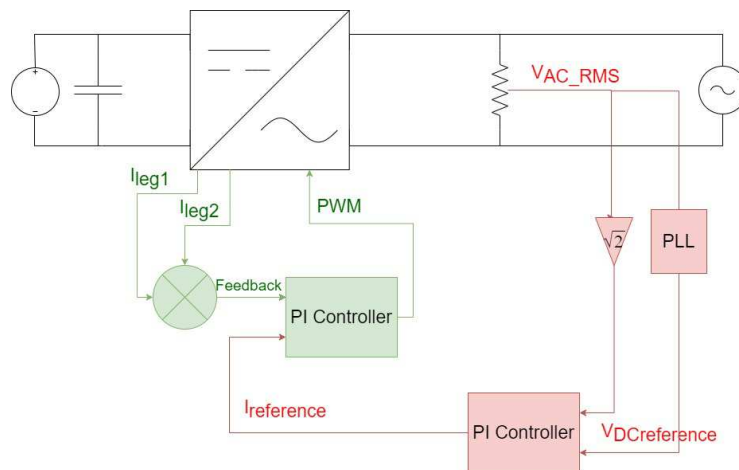

Fig. 4. Loops of voltage and current control
Rys. 4. Pętle sterowania napięciem i prędem

The current control is performed by a loop with the PI controller. First, the current instantaneous value in both branches (I_{leg1} , I_{leg2}) of the inverter bridge is measured. In the physical application, it is performed by the current sensing circuit that measures current by calculating the droop on the shunt resistor at the low side of the inverter branch. Then, the voltage drop is transmitted via an integrated circuit with an operating amplifier that will process the signal to the correct level to the Analog-to-digital converter (ADC), where inside the control unit these values are used to generate PWM value with the use of appropriate transmittance formula according to the chosen that could be PI or PR controller. When selecting the appropriate shunt resistor, the important thing is to choose proper value as well as the tolerance and temperature coefficient that affects the accuracy of the measurement. Also, the method of placing the shunt resistor at the low-side cannot detect shorts to ground, but the voltage that is measured is lower than in the case of placing the shunt resistor inline or at the high-side, so every time the circuit is designed, this tradeoff has to be considered. Similarly, the output voltage is sensing and computing and those circuits are presented in Fig. 5.

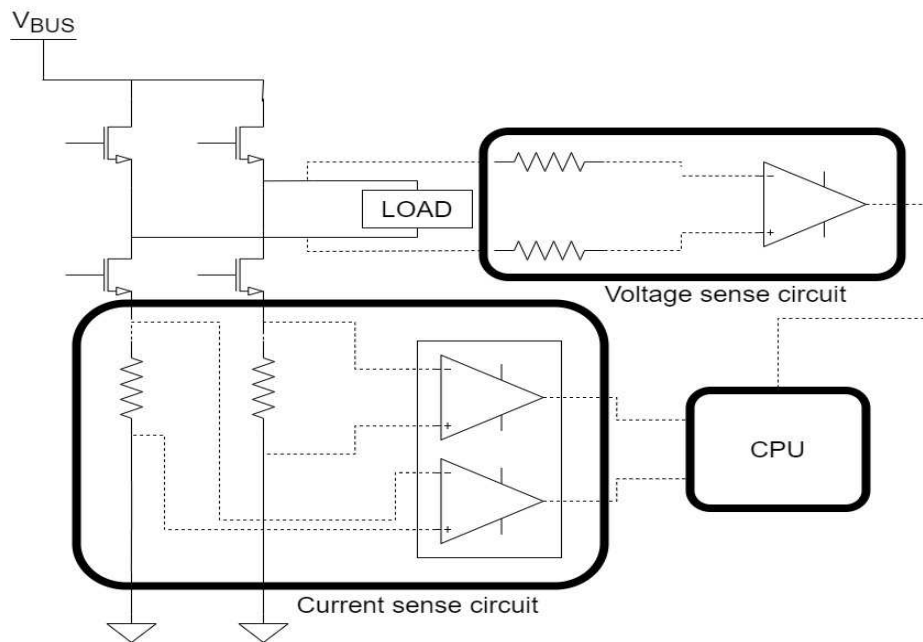

Fig. 5. Current and voltage sensing loops

Rys. 5. Pętle pomiaru prądu i napięcia

Depends on the mode, that system is working (grid-tied/island) the only value that is changing in the circuits is the reference point for the voltage control loop. In the case of the grid-tied mode, the reference value is the main grid voltage. When the island mode is active, then it is necessary to include an artificial sinusoid waveform with desired parameters. That is possible to achieve with the use of libraries that can generate the desired waveform based on the parameters like frequency, phase, gain, etc.

3.2. Grid synchronization mode

One of the most important tasks of the system is the stable and reliable ability to synchronize with the utility grid. In recent years, there has been a dynamic increase in the application of systems that draw energy from renewable sources such as solar energy, which can simultaneously cooperate with the energy grid. Appropriate standards are regulating the operation of inverters in distributed systems. Currently, standards for most countries use the IEEE 1547 Interconnection of Distributed Generation document. This document describes the technical specifications and testing of such systems. It contains general recommendations, required behavior in exceptional situations, as well as the key to the presented project, that is explaining the procedures of islanded work. Additional documents describing distributed systems are IEC 61727, in which one can find islanded work detection procedures; IEC 61000 that defines the harmonic limits that can be put into the network, as well as the EN 50160 standard, in which one can read the basic requirements for energy quality like THD level, variations in voltage amplitude or frequency deviation. Online measuring of grid parameters is key to achieve synchronization. The power converter that is interfaced with the grid must match parameters of its output waveform to the grid waveform. The crucial parameter is the phase angle. Only when the phase angle is matched two sources will not "fight" for the load. It can be only done when the instantaneous monitoring of grid parameters will be made, so in the occurrence of different kinds of disturbances, the secondary source can adjust to the grid phase.

The most widely used and most researched method to ensure synchronizing with the grid is the implementation of the phase-locked loop (PLL). This structure is based on a feedback loop signal that is compared with a reference signal which is the grid voltage measured and then an error signal is produced. The error signal is minimized by internal components that are using oscillators for keeping the phase of the grid synchronized. The lock of the signal is propor-

tional to the performance of this system. The structure of this system contains three basic functional blocks:

- Phase Detector (PD) - the main purpose of this block is to compare the input sinusoid with the locked sinusoid and produce signal error out of it.
- Loop filter (LF) - it is a low-pass filter that clears the error signal by damping output noises and high frequencies from the signal.
- Voltage Controlled Oscillator (VCO) - this block produces the output signal as well as the locked signal with respect to the nominal frequency.

Unfortunately, the grid frequency can be close to the cut-off frequency of the Phase-Locked Loop. Therefore additional blocks in the PLL system are required. Some of the approaches to enhancing PLL structures using Adaptive filtering or Second-Order Generalized Integrator. In both of the methods, the loop filter transfer function must be implemented and the coefficients of that filter have to be calculated with the discretization previously performed. The values have to be thoroughly calculated and tuned with the use of a proven method like Ziegler-Nichols or Cohen – Coon method. The damping ratio and natural frequency are other important parameters to obtain, while the transmittance of PLL is calculated. Hints for defining those parameters can be found in [7]. One of the approaches to deal with the harmonics is to include another filter, that is the notch filter between PD and LF. This type of filter in opposition to the conventional filter is capable to adjust its parameters using only the cost function. Another approach of filtering out the second harmonics uses the second-order integrator for generating (SOGI) the orthogonal frame and after that, the signal is modulated with the park transformation. The software for synchronizing requires only the parameters of the output voltage, that can be sensed with the use of the circuit described in 3.1.3.

3.3. Anti-islanding protection

Securing against the island work is an important issue. It has a direct impact on the grid network and customers security. Currently, standards in most countries do not allow powering the consumers that cooperate with the grid through the backup sources without connection when the unintentional islanding occurs. That affects the creation of truly independent MG. Documents that are describing these laws are included in IEEE1547 and UL174. The islanding can be intentional or unintentional [9]. The first one is planned in advance and agreed by all parties involved. During unintentional islanding, for example, resulting from the power outage in the grid, according to the laws, in most countries, the converter must be disconnected from the receiver within 2 seconds. It should hap-

pen, when the power outage or other undesirable phenomena preventing distributing the energy to the receiver takes place. In accordance with the standards, the converter cannot work independently, because it can pose a threat to people performing works on power lines as well as the possibility of a large phase jump when connecting the power back to the grid. This issue can be eliminated by forcing other principles of SG, for example, smart meters and self-healing. There are many methods for detecting the islanding operation. They can be divided into two groups: remote and local. Remote methods usually require advanced infrastructure and are quite expensive. As for the local methods, they can be divided into two subcategories: passive and active. The passive methods are based on the monitoring of online network parameters (frequency, phase, amplitude, harmonics), while the active methods work by injecting a small interference into the system and observing its response (Perturb and Observe). The active methods are more complex and they test the grid's response to injecting frequency, voltage or interference into the grid signals, or based on an additional PLL loop. Therefore, they require central processing unit to generate interrupts and designing proper priorities within interrupts' groups and enable the safe disconnection of the inverter from the grid, while managing constantly grid output parameters. The active methods overall can better detect anti-islanding operation and take security of given distribution energy system to the higher level, but these methods are very complex to implement and perform.

The most important parameter determining the quality of a given method is the NDZ - None Detection Zone. It measures the reliability and the performance of the detection method, and it is related to active and reactive power flow in PCC, as presented in Fig. 6.

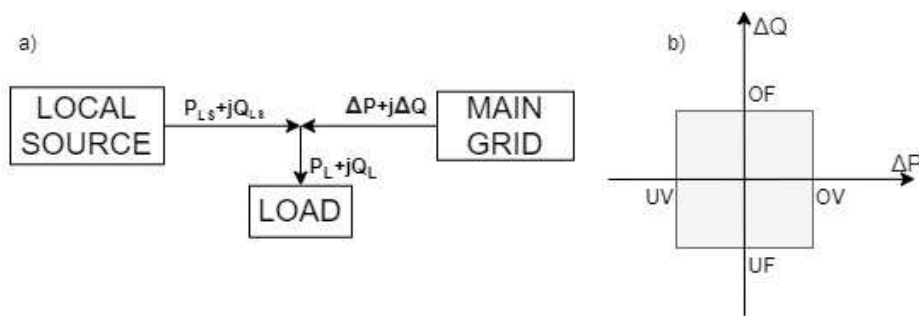

Fig. 6. a) Power flow at PCC b) NDZ
Rys. 6. a) Rozpływ mocy przy PCC b) NDZ

In the emulator, due to the simplicity and widespread use, at first, the combination of methods detecting voltage and frequency changes were used. This method relies on monitoring the grid parameters around the PCC. The controller unit sets the appropriate level of the switch disconnector operation. When it exceeds, the inverter is safely disconnected. According to the fact that the output voltage can vary at most $\pm 10\%$, when the voltage on PCC decreases below 21.6V or increase above 26.4V, the transistor of inverters have to be tripped. In the case of the frequency, in pursuance of the standards documents, the grid frequency can vary at most 1Hz, which gives the allowable range between 49 and 51 Hz. That simplifies the algorithm, which has to only read the output voltage and frequency to obtain the islanding.

To track and sense the parameter circuits the system requires software that in real-time can calculate Root Mean Square (RMS) Voltage and frequency. The voltage sense circuit can be used, as described in 3.1.3. For the emulator, the module provided by Texas Instruments from *Solar Library* was used. It accumulates the sampled sine wave, check for the crossing point and based on this data calculate the RMS and frequency [10]. The value from the voltage sensing circuit is transmitted to the ADC within the controller unit(Slave). The data starts to collect after the zero-crossing point, that is the point, where there exists the change of sign of the value between two samples. The data starts accumulated until the next two crossing points. Then, the collected data are squared and added to each other. The frequency, however, is calculated by sampling frequency defined a priori divided by the number of samples between crossing points. That approach allow to track the output wave parameters in real-time.

3.4. Measurements

The prototype circuit was made and tested. The laboratory station is presented at Fig. 7.

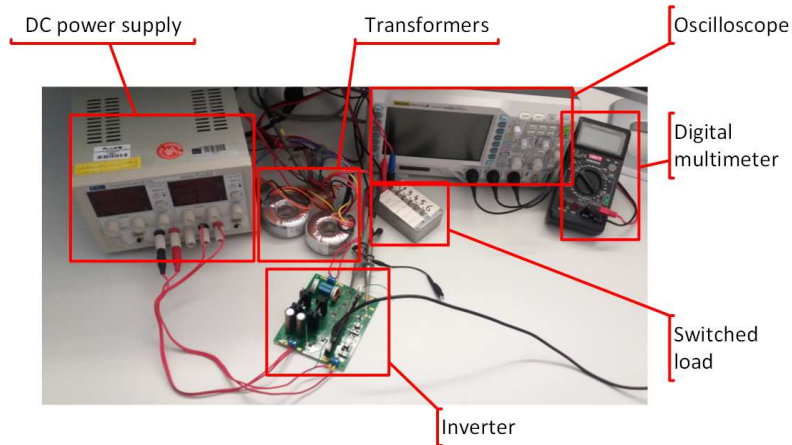

Fig. 7. Laboratory station
Rys. 7. Stacja laboratoryjna

The scheme of the measuring circuit with specified signals is presented in Fig. 8.

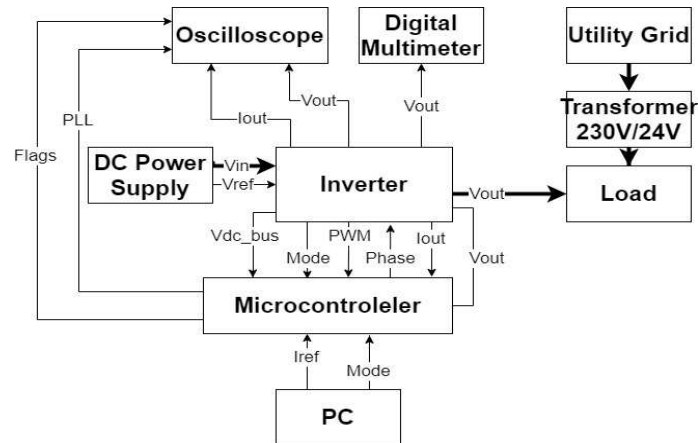

Fig. 8. Circuit diagram of the measuring station.
Rys. 8. Schemat obwody stanowiska pomiarowego.

The two main tests concern the grid-synchronization and the anti-islanding detection. The results were captured on the Fig. 8.

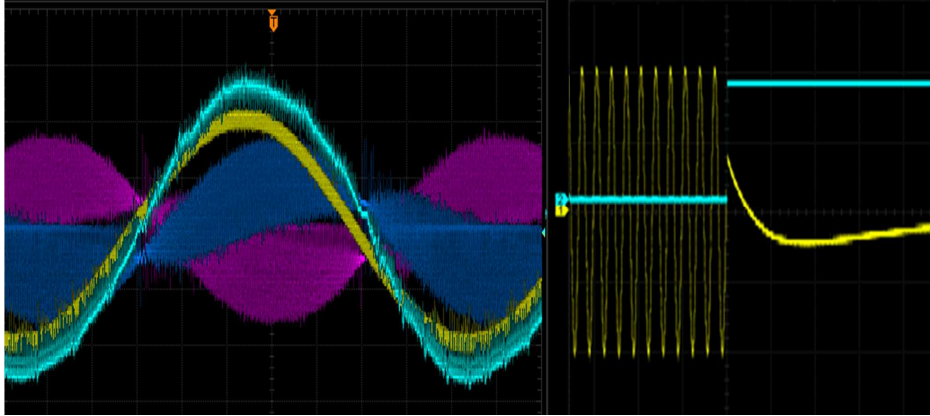

Fig. 9. Grid synchronization and anti-islanding detection oscillograms
Rys. 9. Oscylogramy synchronizacji z siecią i wykrycia pracy wyspowej

At the left oscillogram, the grid-synchronization is captured. The yellow channel is the reference signal, and the light blue channel is the output voltage. The other two channels are the branch currents. There is a small delay between the PLL signal and voltage on the receiver but this is not causing any trouble.

The second oscillogram tested the scenario with an unbalanced frequency, to detect anti-islanding. The frequency was slowly shifted from 50Hz to 60Hz. When the frequency reached more than 51 Hz, the flag was being set and the control unit has the information to trip all transistors of the inverter.

4. CONCLUSIONS

The work presented the generic system of the inverter that can be used in the smart grid application. The main sensing circuits to measure the most crucial parameters were presented. The control methods that can be used in the SG emulator were briefly explained, as well as was the synchronization method. The anti-islanding detection is key for proper MG operation and compliance with the standards. The results were presented at the oscillograms. That inverter model takes advantage of the fact, that it can be very flexible. That is it can work emulating different sources and can work with different loads. Plenty of methods for controlling can be applied and it can be stacked in bigger sys-

tems. With the use of that emulator variety of scenarios can be tested before implementation in the physical grid will be made.

It is important to emphasize, that the inverter model still requires lots of other tests. It will be focus of future work. For example, another power control techniques can be implemented. What is more, the above inverter could be also replaced with the three-phase system, and then another controlling strategy, as well as synchronization techniques, can be applied. Also, it will be worth testing the emulator in a mode when the energy produced from distributed sources can be fed into the grid. Moreover, it would be useful to test the system in parallel work of multiple inverters.

5. ACKNOWLEDGMENTS

This work was supported by the European Regional Development Fund within the BB-PL INTERREG V A 2014-2020 Programme, “reducing barriers – using the common strengths”, project SmartGrid Plattform, grant number 85024423 and by the by the European Union ebalance plus project under the H2020 grant no. 864283. The funding institutions had no role in the design of the study, the collection, analyses, interpretation of data, the writing the manuscript or decision to publish the results.

BIBLIOGRAPHY

1. Buchholz B. M., Styczynski Z.: Smart Grids - Fundamentals and Technologies in Electricity Networks, Springer-Verlag, Berlin, 2014.
2. Bush S. F.: Smart Grid: Communication-Enabled Intelligence for the Electric Power Grid, Wiley-Ieee Press, New Jersey, USA, 2014.
3. Park C., Cho S.: Analysis on trends and future signs of smart grids, International Journal of Smart Grid and Clean Energy, tom 9, nr 3, pp. 533-543, California, USA, 2020.
4. Venkatraman R., Khaitan S. K.: A survey of techniques for designing and managing microgrids, 2015 IEEE Power & Energy Society General Meeting, Denver, CO, USA, 2015.
5. Behera R. R., Thakur A. N.: An overview of various grid synchronization techniques for single-phase grid integration of renewable distributed power generation systems, International Conference on Electrical, Electronics, and Optimization Techniques (ICEEOT), Chennai, India, 2016.

6. Zhong Q.-C., Hornik T.: *Control of Power Inverters in Renewable Energy and Smart Grid Integration*, John Wiley & Sons Ltd, United Kingdom, 2013.
7. Teodorescu R., Liserre M., Rodriguez P.: *Grid Converters for Photovoltaic and Wind Power Systems*, Wiley-IEEE Press, United Kingdom, 2011.
8. Piotrowski K., Powroznik P., Miczulski W., Szulim R.: *Emulating Energy Grids using the e-Balance Emulator*, 12th Conference on Measurement Systems in Research and Industry (MS 2018), 115, Poland, 2018.
9. Piotrowski K., Garrido D., Chen J.: *The e-Balance Platform for Managing Energy in Smart Grids*, Proc. 12th Conference on Measurement Systems in Research and Industry (SP2018), 119, Poland, 2018.
10. Hossain Md A., Pota H. R., Issa W., Hossain MD J.: *Overview of AC Microgrid Controls with Inverter-Interfaced Generations*, *Energies* , tom 10, nr 9, Basel, Switzerland, 2017.
11. Bansal R., *Handbook of Distributed Generation*, Springer, Switzerland, 2017.
12. C28x Solar Library, v.1.2, Texas Instruments Inc., 2014.